

Teaching through Myth and Metaphor

A Teacher Workshop

January 22, 2000

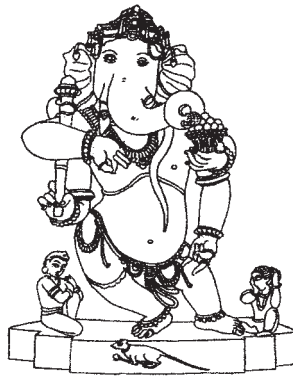

Contents

Kavad: Storytelling Box from India
Background
Lesson Activities
Vocabulary
Bibliography
Hindu Folktale
Map of India

Kamishibai: Japanese Storytelling
Background
Lesson Activities
Vocabulary
References (websites)
Japanese Folktale
Map of Japan

Prepared and Illustrated by
Stephanie Kao



Storytelling Teacher's Workshop

by Margaret Read Macdonald

January 22, 2000

Contents

About the Presenter
<i>Roly Poly Rice Ball</i>
<i>Siddhartha Encounters the World</i>
<i>Siddhartha Vows to Attain Enlightenment</i>
<i>Mucalinda</i>
<i>Buddha's Enlightenment</i>
<i>Rich Man Seeks a Daughter-in-Law</i>
<i>How to Learn</i>
<i>Not our Problem</i>
<i>The Magic Fox</i>
<i>Girl Who Wore Too Much</i>
<i>Elephant and the Bees</i>
<i>Little Rooster and the Heavenly Dragon</i>
Asian Folktales Bibliography
Favorite South East Asian Tales for Telling
Playing with Story Bibliography

Kavad: Storytelling Box

The tradition of storytelling with picture has existed in India since the second century BCE. It provides an entertaining and educational method for relating religious scriptures of Hinduism: the *Vedas*, *Mahabharata* (the world's longest poem) including the *Bhagavad-Gita*, *Ramayana*, *Puranas*, and *Tantras*. The telling of a story also allows a way for the illiterate and those who cannot travel to a temple to gain merit and communicate with the deities. A popular folk art storytelling device used in Rajasthan and Madhya Pradesh, India is the *kavad*. The *kavad* is a story box made of light wood measuring 80 centimeters (30 inches) high. It opens up to reveal multiple folding doors, each painted with brightly colored scenes of Hindu mythology. The story box itself is revered as a portable shrine and has the status of a sacred object. The *kavad* may be a shrine to the Hindu god of Vishnu in which each door depicts scenes of Vishnu's life. As a story progresses, the *bhopa* unfolds each new door until the entire box has been opened. The story ends with center of the box revealing an image of a deity, usually a 3 dimensional figure in a frontal position, giving *darshan* (direct eye contact of a divine image). The story box is used by the *bhopa*, a traditional ballad singer whose performance skillfully blends oral narration, dance, music accompaniment, audience participation, and folk art into a spiritual and entertaining experience for listeners.

The *kavad* and other picture storytelling devices in India display specific artistic techniques and composition used in Indian folk art. Because the audience relies on artistic and iconographic clues to recognize story characters, the artist must be consistent in using specific colors and symbolic objects throughout an art piece. It is also important that the painter uses color and composition to draw an audience into a story. A technique often used is a figure in profile facing another figure in profile at opposite ends of a scene. This intensifies the action occurring in a particular scene and separates it from the following one. Borders, trees, rivers, buildings, and the posture of human figures divide scenes and help direct the audience's attention. Color is also a very important element of folk art. The traditional colors used by painters include: orange = human body, red = dresses, green = nature/dresses, light colors = dreams, yellow = ornaments, gray = architecture, and black = outline. Colors that identify Hindu deities: red = *Brahma*, blue = *Vishnu*, and white = *Shiva*.

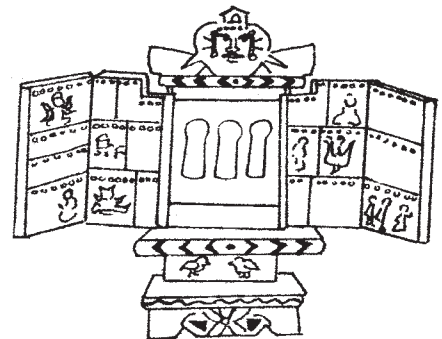
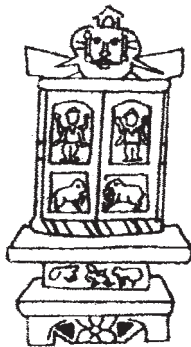

Kavad

By Stephanie Kao

Lesson Objectives

- Students will create a *kavad* storytelling box and paint illustrations of their own life experiences.
- Students will learn the history of *kavad* and the storytelling tradition in India.
- Students will gain an awareness of Indian culture, customs and values.

Materials

a box, red construction paper, tempura paint, scissors, x-acto knife, glue, and a ruler.

Vocabulary

kavad, *bhopa*, shrine, profile, deity, symbol, and iconography

Teaching Strategies

Locate the states of Rajasthan and Madhya Pradesh, India on a map. Discuss the role and importance of a storyteller in India. Discuss the Hindu mythology and the reasons why the telling of these stories have spiritual meaning to the people of India. Show examples of Indian folk art painting and analyze the use of color and composition. Ask students how the bright colors and black outline used in Indian art make them feel. Have students select an animal and symbolic object to represent themselves. Students will then explain their selections.

Procedure

Using a ruler, draw a large square on the cover a box. Draw a vertical line down the middle of the square. Cut the top, bottom, and centerline of the square with a x-acto knife. The two panels will be able to open up like a door. Measure and cut out four pieces of construction paper the same size of a door panel. This can be done with a ruler by tracing the shape of the panel onto paper. Take two pieces of paper and draw a total of four equal sections (two sections per paper). On the next two papers, students can continue to draw more sections. The first two pieces of construction paper will cover the front of the *kavad* panels, and the other two papers will be placed inside.

1

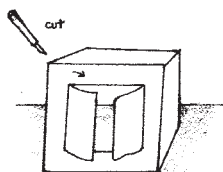

2

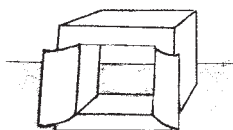

3



4



5

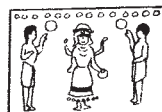

6

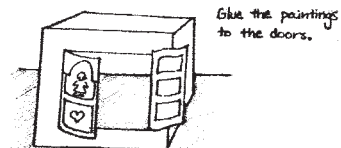

Encourage students to draw and then paint important individuals, events in their life, and symbols that represent their personality. They may want to emulate traditional Indian folk art by painting people at opposite ends of a section using the profile-facing-profile technique. Horizontal rows of white dots, trees, rivers, and buildings can be also be used as scene dividers. Once the pictures are dry they can be glued onto the doors of the box. Paint the entire inside of the box with red paint. This will be the background for the center figures of the *kavad* box.

Creating center figures for the kavad

Materials

large clothespins, white paper, color pencils, marker, and glue.

Procedure

Color the clothespins with bright color markers. Trace around the clothespins and use this as a body frame for designing cloths. Draw in the cloths and make sure to include the arms. Outline the picture with black marker, cut it out, and glue it to a clothespin. Students can then draw facial features and hair with a black marker onto the top of the clothespin. Once student finish making their center figures, they can then be glued to the back inside of the *kavad* box.

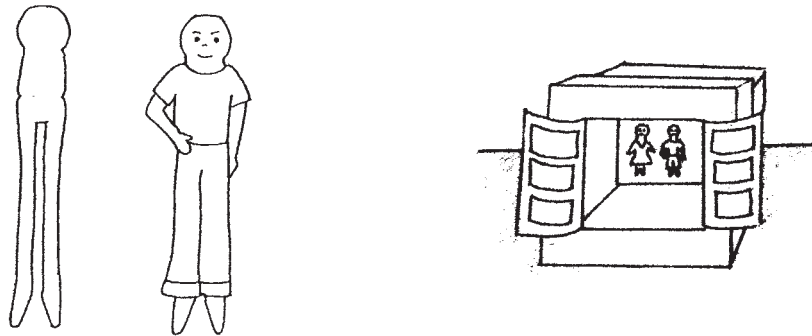

Extension

Teachers can also make this project using a tagboard folder instead of a box. Students can cut out doors on the front of a folder using scissors. They can then draw and paint in the story sections and also paint the center figures on the inside of the folder.

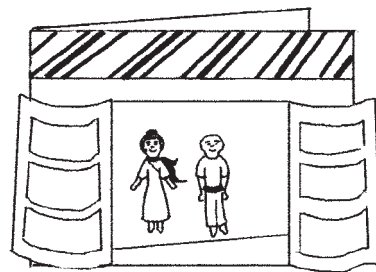

Suggested Activities for Hindu Storytelling

Where is India?

Show the students where India is on a globe, work map, or atlas. Compare its size with that of the United States. Measure the distance in miles from San Francisco to New Delhi, the capital of India, or calculate the distance in hours in an airplane.

How do you say hello in India?

Namaste (nah mahs day) is used for both hello and goodbye and means “the god in me greets the god in you.”

What are myths?

Myths are stories from pre-history, sacred to the people who told them.

What are Hindu myths?

The Hindu religion is based on the belief in one absolute, timeless, unending source of all creation. However, this one source is worshipped in the form of innumerable gods, of which the three central ones are *Brahma*, the creator, *Vishnu*, the preserver, and *Shiva*, the destroyer. There are also demons or anti-gods, who have great power and constantly fight the gods. The demons are sometimes temporarily victorious, but when the gods combine their forces, they always overcome.

What are gods and goddesses?

Introduce and discuss some of the major Hindu gods and goddesses. See vocabulary list.

How do the gods and goddesses get around?

They use vehicles: Introduce and discuss the special animals that are the vehicles of the gods.

Garuda: an animal with the head of a vulture and the body of a man, Garuda is the king of the birds and the vehicle of Vishnu

Nandi: a bull, the vehicle of Shiva, he sits at the door of many temples pointing towards the image of Shiva inside

Rat: the vehicle of Ganesha, the elephant-headed god

Peacock: the vehicle of Kartikeya, brother of Ganesha. Also the national bird of India

Goose: the vehicle of *Brahma*, the god of creation

Lion: the vehicle of Durga, the fierce form of the mother goddess

What do the gods and goddess look like?

Art Project: Have each student visualize and draw one of the above gods or goddesses, imagining size, color, number of heads, arms, legs, and expressions. If they prefer, have them visualize and draw one of the vehicles of the gods and goddesses.

Hindu Vocabulary

Bhagavad-Gita	(bhaj: to revere, go: to sing, gita: root) popular text within the <i>Mahabharata</i> , conversation between Lord Krishna and Arjuna on the eve of battle concerning duty and the nature of the cosmos
Brahma	(brih: to expand) God as creator, evolver, emanator, of the Trimurti (Brahma, Vishnu, Shiva)
Brahman	the Supreme Being that pervades all
bhopa	a traditional storyteller who combines singing, dancing, musical accompaniment, and folk art in telling Indian folklore and Hindu mythology
Durga	a very powerful and fierce form of the divine mother goddess, she defeated the buffalo demon who threatened the world
Ganesha	known as the god of wisdom and the remover of all obstacles, Ganesha is the son of Shiva and Parvati. He has the head of an elephant
Kartikeya	another son of Shiva and Parvati; also known as Skanda, the god of war
kavad	a painted wooden mobile shrine carried by travelling storytellers in Rajasthan and Madhya Pradesh, India. The story box has multiple folding doors, each painted with scenes of Hindu mythology
Lakshmi	the wife of Vishnu, a loving form of the divine mother goddess, and goddess of love, beauty, and wealth
Mahabharata	holy scripture, the epic of the descendants of Bharata; world's longest poem; tells story of the conflict between the Pandavas and Kauravas for control of northern India; includes the <i>Bhagavad-Gita</i>
Parvati	the wife of Shiva, and another loving form of the divine mother goddess. Also the mother of Ganesha and Kartikeya
Rama	great hero who fought the demon Ravana, who had kidnapped Rama's beloved wife Sita
Ramayana	the epic story of Rama, an avatar of Vishnu and Sita; Sita's abduction by Ravana, and subsequent vanquishing of Ravana by Rama, assisted by a monkey army; composed of 48,000 lines of 16 syllables, divided into 7 books; part of the sacred literature of Hinduism
Shiva	one of the three major Hindu gods, with Brahma and Vishnu. Shiva both destroys life and recreates it

Veda	(knowledge, wisdom) sacred scriptures (sruti) of Hinduism, possibly composed before 2000 BCE consisting of thousands of verses and prose. The four Vedas (as arranged by Vyasa) are: <i>Rg, Yajur, Sama, Atharva Veda</i> . Each contains hymns, priestly manuals, 'forest treatises' and enlightened discourses
Vishnu	the preserver of life. To save earth, he incarnated himself many times, as a fish, tortoise, a boar, Rama, Krishna, and in some beliefs, Buddha

Kavad Bibliography

Barnard, Nicholas. *Arts and Crafts of India*. London: Conran Octopus, 1993

Cooper, Ilay and Gillow, John. *Arts and Crafts of India*. London: Thames and Hudson Ltd., 1996

Jain, Jyostindra. *Picture Showmen – The Living Arts of India: Insights into the Narrative Tradition in India Art*. Mumai, India: Marg Publications, 1998

Joshi, Om Prakash. *Painted Folklore and Folklore Pinters of India*. Dehli: Concept Publishing Company, 1976

Kramrisch, Stella. *Aditi – The Living Arts of India*. Washington D.C.: Smithsonian Institution Press, 1985

Singh, Kavita. *Picture Showmen – The Living Arts of India: To Show, To See, To Tell, To Know*. Mumai, India: Marg Publications, 1998

Kamishibai

By Stephanie Kao

Kamishibai (kami-paper, shibai-play) is a popular Japanese storytelling art form that combines oral and visual narration. In Japan during the 1920s–1950's, the *kamishibai* storyteller entertained children with his telling of Japanese folktales while displaying colorful pictures to describe each scene. The manner in which the *kamishibai* storyteller tells his stories is what captivates children. The storyteller rides into town on a bicycle sounding wooden clappers to notify children of his arrival. On the back of the bicycle is a wooden *kamishibai* box. Curved panels on both the sides and top of the box frame the box. These panels open up to resemble a small stage with a cutout screen that holds 12-16 wood block prints.

As children gather around the storyteller and the *kamishibai* box, he sells candy lollipops and proceeds to tell a Japanese folktale. The storyteller displays a picture with each story scene and slides them out to reveal the events of the next scene. Just when the story reaches an exciting part, the storyteller stops and promises to continue the tale the following day. The storyteller made his living by candy sales and he would ensure a large audience by providing appealing *kamishibai* pictures and by maintaining narrative suspense. At a time when there was no television and few cars, the storyteller was a greatly entertaining and is fondly remembered by many Japanese.

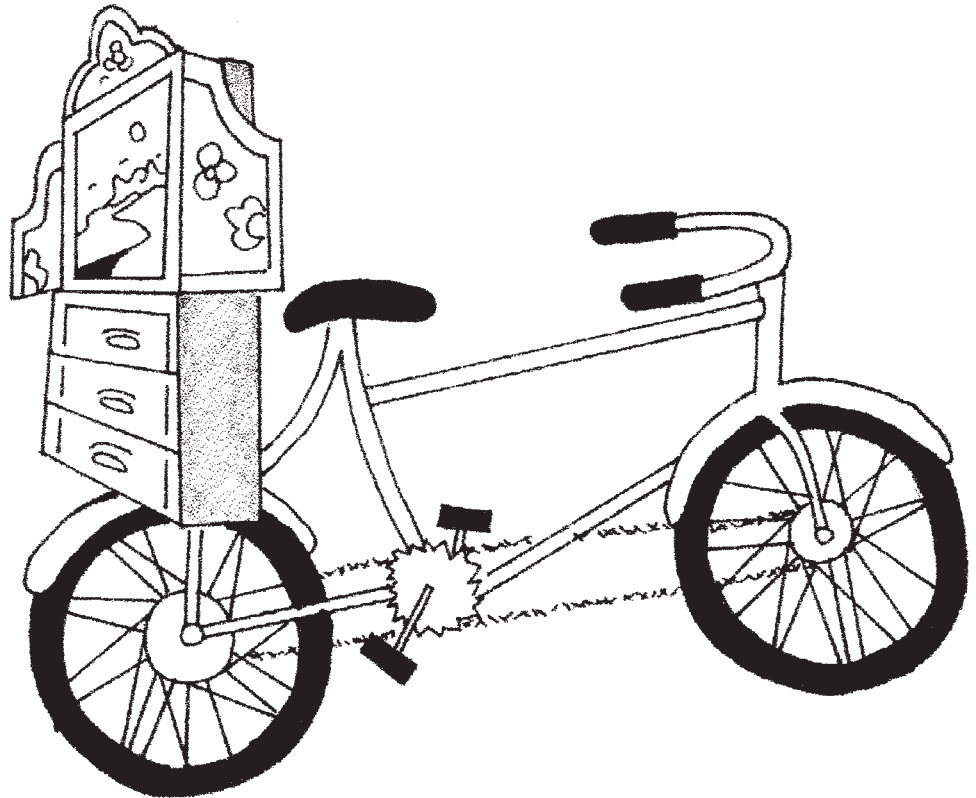

Mini-Kamishibai

By Stephanie Kao

Lesson Objectives

- Students will create a pocket size version of *kamishibai* and illustrate a Japanese folktale.
- Students will learn the history of *kamishibai*.
- Students will use oral, written, and visual language in presenting Japanese folktales.
- Students will discuss the similarities and differences in American and Japanese story-telling traditions.
- Students will gain an awareness of Japanese culture and Japanese society in early to mid 20th century.

Teaching Strategies

Present students with an introduction to Japanese culture and customs. Discuss with students how folk tales reveal the culture, customs, and values of people from different countries. Ask students to name several European folk tales and discuss how these stories reflect the values of its people. Describe the role of a Japanese storyteller and *kamishibai* in 1920s–1950's. Explain to students how *kamishibai* gave young children in Japan great entertainment at a time when there was no television and few cars. Share several Japanese folk tales with your class and discuss with students their interpretations of Japanese traditional customs and culture.

Materials

a small box (jewelry boxes work the best), decorative paper, x-acto knife, glue, pencil, and a ruler.

Procedure:

Using a ruler, draw a square on the lid of a small box. Cut out the square with an x-acto knife (teachers or parents will need to do this for young children). Place the lid and the bottom part of the box together and cut a thin rectangle on a side of the bottom box. The cut should be the same width as the square cut from the lid.

Glue and wrap the box lid:

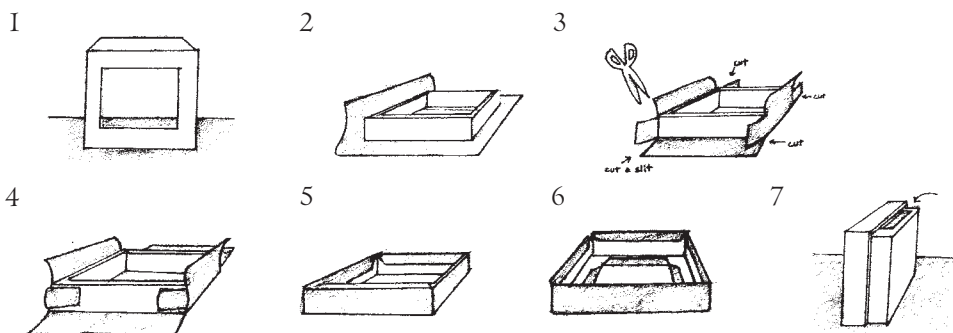

Follow the same instructions for wrapping the bottom part of the box. The paper will need to be cut and wrapped inside the side slit. Put the box together and you will have a mini-*kamishibai* box!

Mini-Kamishibai Cards

By Stephanie Kao

Materials

tag board or thick white paper, scissors, marker, color pencils, and crayons

Procedure

Have students select their favorite Japanese folk tale. On a piece of paper, students write a summary of the folk tale and divide it into 10 segments. Segments can be numbered according to the introduction of new characters and events in a story. Make sure that students make a title card.

Cut 11 rectangle cards the width of the square (cut from the lid) and the length a 1/2 inch longer than the size of the box. Students will number the cards in the top right corner 1-11. Write a brief description of each story segment onto the cards according to the card number. The back of card #11 should be left blank.

In traditional *kamishibai*, the back of each card has a description of the upcoming picture. This enables the storyteller to refer to the back of a card to describe the next picture. For example, the back of the title card will show a summary of the picture card #2. If this is too difficult, students can match the written story segment with each picture. They can then memorize each card for their storytelling.

Student can show off their drawing skills by interpreting and drawing each scene with markers, color pencils, and crayons.

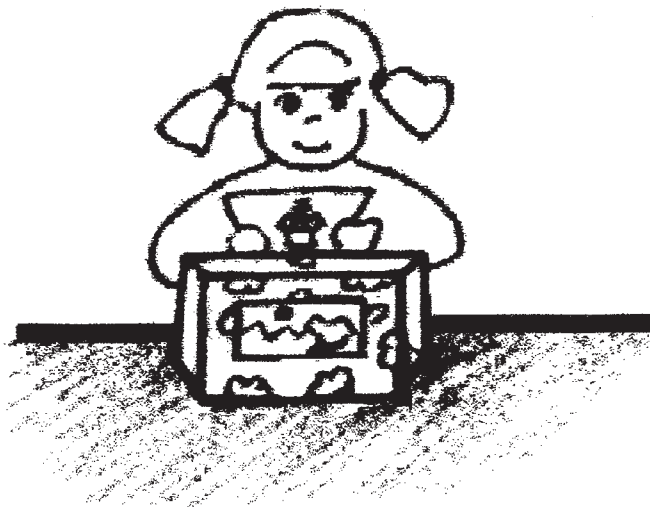

Contextual Drama

Pretend that the classroom is a suburb of Tokyo, Japan in 1930. The *kamishibai* storyteller (teacher) rides into town while clapping two wooden blocks together. The teacher pretends to sell candy lollipops to the children and begins to set up his/her *kamishibai* box. The storyteller begins a story with “Mukashi mukashi. . .” or “Once upon a time. . .” and tells a folk tale adventure using colorful illustrations to describe each scene. As the story reaches an exciting point, the storyteller stops and the children must wait in suspense until the storyteller visits the town again.

Teachers can build their own classroom *kamishibai* box and make color photocopy illustrations to be used for *kamishibai*. Teachers can also make regular “*kamishibai* visits” to the class so that students gain a sense of excitement and suspense that make *kamishibai* so much fun.

Japanese Vocabulary

Buddhism	A belief system based on the teaching of Buddha, the awakened one. These teaching help us to become truly awake to our own joyful and compassionate nature, which we share with all living creatures
calligraphy	the art of writing beautifully, often done with ink and brush
kamishibai	A storytelling with picture technique used in Japan during 1920s–1950s. A storyteller uses a <i>kamishibai</i> box, a wooden box that resembles a stage and contains wood print pictures to illustrate a folktale.
kimono	a long, loose robe worn by men, women, and children in Japan for special occasions such as holidays, festivals, weddings, etc. The sash worn around the waist with a kimono is called an obi.
Mukashi mukashi	a Japanese saying at the beginning of folktales translating to “Once upon a time.”
origami	The Japanese art of paper folding
samurai	Professional Japanese warrior/soldiers
scroll	A painting or writing on silk or paper that is hung on a wall to be seen and then rolled up when not in use
Shintoism	a belief system practiced in Japan that teaches us the importance of giving great honor to nature and to those who lived before us and have died.
shoji	a sliding wall, usually made of wood and rice paper
symbol	Some Japanese auspicious symbols are: Crane = long life, faithfulness, tortoise = long life, and lotus flower = enlightenment, purity.

Japanese Language

Learn some basic Japanese words and expressions to practice.

good morning	O-hayo gozaimasu (oh hi yo goh zye ma su)
good afternoon	kon-nichi-wa (kohn nee-chee wah)
hello	moshi moshi (moh shee moh shee)
goodbye	sayonara (sigh yoh nah rah)
teacher	sensei (sen say)
child/children	kodomo (koh doh moh)
thank you	arigato (ah ree ga toe)

Count from 1-10 in Japanese

1	inci (ee chee)
2	ni (nee)
3	san (sahn)
4	shi (shee)
5	go (goh)
6	roku (roh-koo)
7	shichi (see-chee)
8	hachi (ha-chee)
9	ku (koo)
10	ju (joo)

Japanese Pronunciation Guide

Pronounce all vowels separately and distinctly:

a	as in father
e	as in led
i	as the double ee in see
o	as in obey
u	as the oo root

Consonants are mostly as in English, except:

g	is always hard, as in gum
r	is very soft, not rolled or glottal

Double consonants kk, nn, pp, ss, tt, take an extra beat, as if one paused or hovered over the sound

Two notes:

tsu	is the only really difficult sound for English speakers; it begins with a plosive click
-----	---

su and tsu when in the final position or followed by a consonant sound
may lose almost completely the u sound and end up sounding like a nearly
pure s or ts; for example the copulative erb desu, though for emphasis or
extreme politeness might be sounded out clearly as two syllables de-su,
most often sounds like dess in usual conversation.

Websites on kamishibai

<http://busd.k12.co.us/curriculum/links/japan.html>

http://langue.hyper.chub.ac.jp/jalt/pub/tilt/97/dec/sh_rowe.html

<http://www.smith.edu/fceas/curriculum/peet.html>

<http://www.gwjapan.com/matsur/kami.html>
